



Certified ISO 9001

# **Genesis II Select Directional™**

## User's and Installation Manual



Decatur Electronics, Inc.  
715 Bright Street, Decatur, IL 62522

USA/Canada 800.428.4315

Intl 217.428.4315

Fax 217.428.5302

[www.decaturradar.com](http://www.decaturradar.com)

## WELCOME TO DECATUR ELECTRONICS

Thank you for choosing another fine Decatur Electronics product—a *Genesis-II Select Directional™*, a highly advanced traffic radar unit that will reward your department with years of dependable service. The *Genesis-II Select Directional* design incorporates high performance and long range, with many leading features.

We urge you to study this manual before using the *Genesis-II Select Directional*, so you can maximize the benefits of this sophisticated radar device. We believe you will be pleasantly surprised by the features and advantages. The *Genesis-II Select Directional* is small, dependable, features instant target acquisition, and is designed using a quality management system certified to ISO 9001. Its digital signal processing (DSP) gives the device advanced capabilities unseen by many veteran officers. If you are as pleased with its performance as we think you will be, ask your Decatur sales representative about other Decatur products, including the *Genesis VP™* Black & Decker® VersaPak™\* battery hand-held line of products.

Traffic officers told us exactly what they wanted in a radar device—and we built it. Try any one of our products and see if you don't agree that it is the best-in-class!

—The management and staff at Decatur Electronics,  
the nation's oldest radar company

\* VersaPak is a registered trademark of the Black & Decker Company.

## TABLE OF CONTENTS

<i>Genesis-II Select Directional™</i> Features.....	5
1. Quick Start .....	7
2. Installation .....	8
2.1 Separating the Computer/Display Unit (optional).....	8
2.2 Mounting the Computer/Display Unit .....	10
2.3 Mounting and Connecting the Antenna .....	13
2.4 Installation Check .....	16
3. Operating the <i>Genesis-II Select Directional</i> .....	17
3.1 Power .....	17
3.2 Front and Rear Antenna .....	18
3.3 Stationary Mode .....	19
3.4 Moving Mode Opposite Direction .....	23
3.5 Moving Mode Same Direction .....	24
3.6 Faster Mode .....	26
3.7 Lock a Speed .....	27
3.8 Range Setting .....	28
3.9 Stopwatch Mode.....	29
4. Computer/Display Unit.....	31
4.1 Display Windows .....	32
4.2 Lights .....	33
5. Antennas .....	35
6. Hand-Held Remote Control .....	36
6.1 Control Buttons .....	37
7. Communication System Controls .....	41
8. Performance Tips .....	42
8.1 How Radar Works .....	42
8.2 Interference Sources and Remedies .....	42
8.2.1 Angular Interference (Cosine Effect) .....	43
8.2.2 Fan Interference .....	44
8.2.3 Batching .....	45
8.2.4 Electromagnetic Interference (EMI) .....	45
8.2.5 Feedback Interference .....	45

8.2.6	Multi-Path Beam Cancellation .....	46
8.2.7	Patrol Harmonics .....	46
8.2.8	Radio Frequency Interference (RFI) .....	46
8.2.9	Shadowing .....	47
8.2.10	Vehicle Ignition Interference.....	49
9.	Field Tests .....	50
9.1	Operator-Requested Self Test .....	50
9.2	Road Test .....	50
9.3	Tracking History .....	51
10.	Care, Cleaning, and Storage .....	52
11.	Specifications .....	53
11.1	Mechanical .....	53
11.2	Antenna .....	54
11.3	Environment .....	54
11.4	Power Consumption .....	55
11.5	Accuracy.....	55
11.6	Speed Range .....	56
12.	Legal Requirements .....	57
12.1	FCC Documents .....	57
12.2	Canadian Industry Certificates of Technical Acceptability .....	58
12.3	Radar Case Law .....	59
13.	Frequently Asked Questions (FAQ) .....	60
14.	Service .....	62
14.1	Warranty .....	62
14.2	Service Return Procedure .....	63
14.3	Maintenance and Repair Record .....	65
15.	How to Order Additional Products .....	66
	Appendix A Communications Port .....	68
	Appendix B Menu Feature.....	69
	Appendix C Radar Case Law.....	70
	User Notes .....	81
	Index .....	82



## **Genesis-II Select Directional™ Features**

The *Genesis-II Select Directional™* is a highly advanced traffic radar device offering many advanced capabilities. It includes 32-bit digital signal processing (DSP), a versatile detachable computer/display unit, K-band Directional antennas, and an easy-to-use hand-held remote control. It also features Faster Mode for detecting the next strongest target going faster than the strongest in multiple target situations.

Unlike conventional radars, the *Genesis-II Select Directional* is able to determine *which direction* targets are moving. Directional technology enables the radar to single out vehicles moving in one specific direction, while ignoring vehicles moving in the other direction. This capability makes stationary operation far more effective and makes moving same lane mode very easy to operate.

The *Genesis-II Select Directional* digital signal processing provides instant target acquisition and speed lock as well as more precise tracking and speed measurement.

If space in your vehicle is at a premium, you will appreciate the detachable computer/display unit. For more safety conscious installation options, you can separate the pieces and mount them wherever best meets your specific needs.

The hand-held remote controls all the functions. It features convenient “eyes-off” raised buttons for use without taking your eyes off the road. The remote control fits comfortably in the palm of your hand, positioning all controls at your fingertips.

### **About This Manual**

*Note the following symbols in this manual.*



*indicates a warning message about safety precautions. Please read it carefully.*



*indicates a helpful tip or precaution to note.*

The *Genesis-II Select Directional* includes:



Detachable computer/display unit



Antenna



Hand-held remote



Connector cables

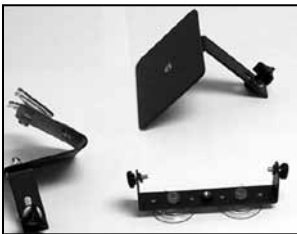

Mounting brackets

## 1. Quick Start

1. Press the **PWR** button on the hand-held remote to power up the radar unit.
2. Press the **ANT FRONT** or **REAR** button to select the antenna from which you want the radar to transmit.
3. Press and release the **MODE** button to quickly toggle between Moving Mode Opposite Direction and Moving Mode Same Direction. Press and hold the **MODE** button for two seconds to activate and then toggle through the three Stationary Modes.
4. Press and hold the **FAST** button to select Faster Mode when you want to track the next strongest target going faster than the strongest.
5. To lock on a target speed, press the **LOCK** button. The target speed will transfer to the **LOCKED** window. The radar will continue to process speeds and display them in the **TARGET** window.
6. To clear a locked speed, press the **LOCK** button when an antenna is transmitting and no target is present. The locked speed will also be cleared in these situations:
  - turn the antenna off and back on
  - turn antenna off and press **LOCK** button
  - turn power off and back on again (not recommended)
  - change modes

## 2. Installation

Use the following instructions to mount your *Genesis-II Select Directional*.

### 2.1 Separating the Computer/Display Unit (optional)

If the space in your vehicle is at a premium, you will appreciate *Genesis-II Select Directional's* compact size and versatile components. You can separate and remotely mount the computer unit from the display unit. Common places to mount it are behind the dash, under the driver's seat, or on the console.

To separate the combined unit, firmly grasp the ends and pull them apart.



Figure 2.1a Separating the computer/display unit.

Note the 9-pin connectors on each half of the unit. Screw two standoffs into the holes next to each connector to attach the two pieces with the 9-pin connector cable.

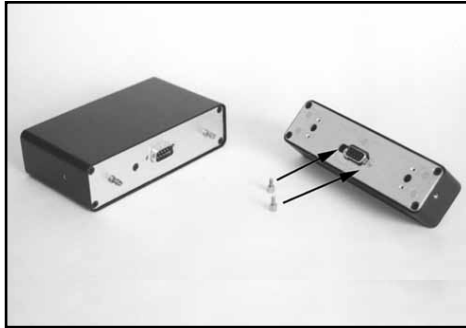

Figure 2.1b To connect the separated unit, first insert the standoffs to secure the cable connectors.

Then attach and secure the connectors with the thumbscrews on the sides of each cable connector.

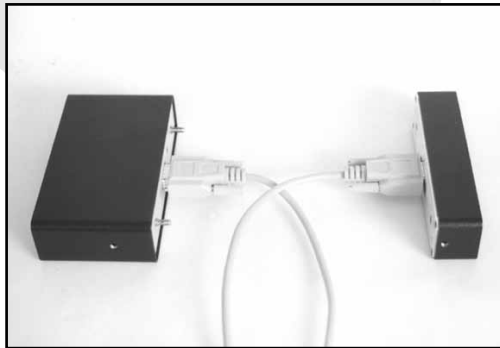

Figure 2.1c Secure the connecting cable by fastening the thumbscrews into the standoffs.

To return the unit to a one-piece configuration, remove the cables and standoffs, line up the 9-pin connectors, and push the two pieces together.

## 2.2 Mounting the Computer/Display Unit



### WARNING

- *Do not place the Genesis-II Select Directional components in locations that will obscure the driver's view of the road.*
- *Double-check each component to ensure it is securely mounted. In an accident, a loose component could strike an occupant of the vehicle.*
- *Do not place the Genesis-II Select Directional computer, antennas, cables, or brackets in your vehicle's air bag deployment zones. Refer to your vehicle's owner's manual or call the vehicle manufacturer if you are unsure where the air bag deployment zones are.*

You can mount the computer/display unit behind and to the side of the steering wheel or on the dashboard. The computer unit easily withstands and remains accurate in temperature extremes. Dash-mounting the unit promotes safety; you can read the display without taking your eyes off the road.

To mount the unit, use the Velcro™ fastening material or the mounting bracket. Before applying the Velcro™, use a clean cloth to remove any foreign material from the dashboard and bracket face. Position the Velcro™ lightly on the computer/display unit and mounting surface. After the unit is in the correct position, press it firmly to affix it to the surface. For the bracket mount, simply place and tighten the screws on the mounting bracket into the holes in the unit. Then adhere the suction cups to a clean glass surface. For maximum adhesion, moisten the suction cups before affixing them to the surface.

Also, if your Police Services has departmentally approved hardware the unit and antennas can be installed on that mounting hardware or the mounting hardware that is provided with the unit.

All cables connect to the rear panel of the computer unit with a quick-disconnect connector. (A communications cable for video and PC is not included. You can order it from Decatur Electronics by calling 800.428.4315.)



Figure 2.2a The quick-disconnect connector plugs into the computer unit.

1. Align the red dot on the connector with the red dot at the top of the receptacle.
2. Push the connector into the receptacle until you hear a click.

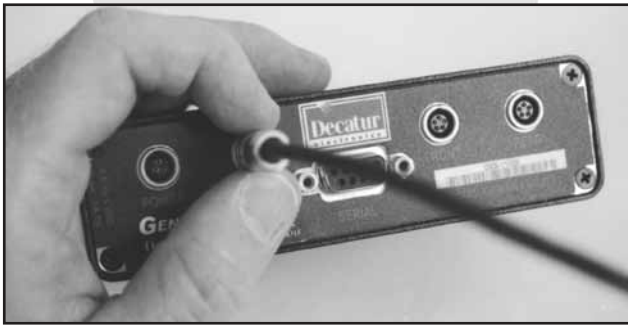

Figure 2.2b Align the red dot on the connector with the red dot on the computer receptacle.

## Power connector



### **WARNING**

*Be sure to plug the connector into the computer unit before plugging the power cable into the auxiliary power source. If the power source is on, it can damage the unit.*

The power cable has a larger 12-volt power plug (cigar plug) on one end. Make sure the plug fits securely in the vehicle's auxiliary power (cigarette lighter) receptacle.



Figure 2.2c The cigar plug for the auxiliary power (cigarette lighter) receptacle.

## Antenna connector

The connector that plugs into the antenna has a more smooth finish than the connectors that plug into the unit.



Figure 2.2d Cable connector that plugs into the antenna.

To remove a cable, grasp and pull the connector.

## 2.3 Mounting and Connecting the Antenna

To attach the antennas to the brackets, align the threaded mounting hole on the antenna with the slot on the L-brace. Then screw the post into the threaded mounting hole.

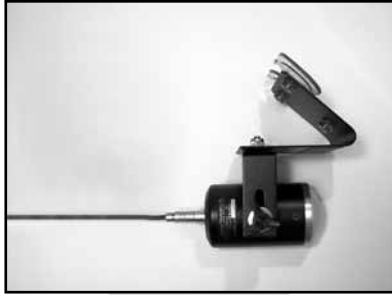

Figure 2.3a The front antenna mounts using the suction cup bracket

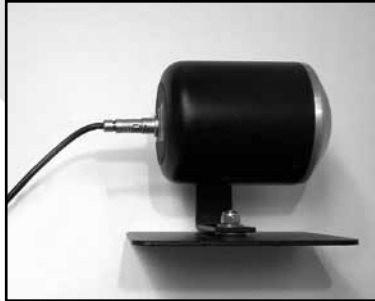

Figure 2.3b The rear antenna mounts using the flat deck mount bracket.

When affixing the suction cup mounted front antenna, for maximum adhesion, moisten the suction cups on the bracket before affixing them to a surface of the glass. Mount the forward-facing antenna assembly on the windshield. Mount the rear-facing antenna near the center brake light where it is not obstructing a clear view of traffic.

After you affix the bracket to a surface, adjust the position of the antenna. **ANY SIGNIFICANT DEVIATION FROM A PARALLEL ORIENTATION CAN AFFECT THE READING OF A VALID TARGET.**

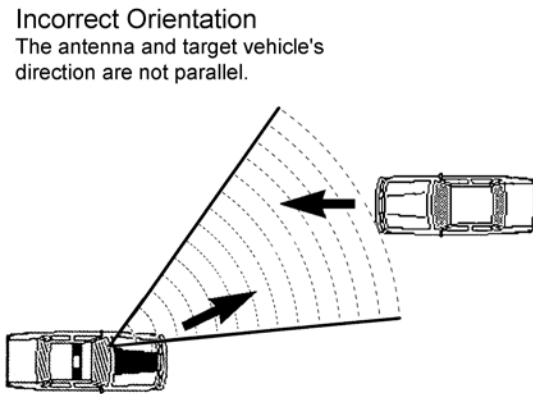
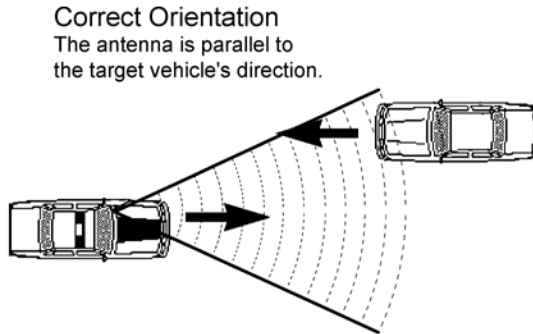
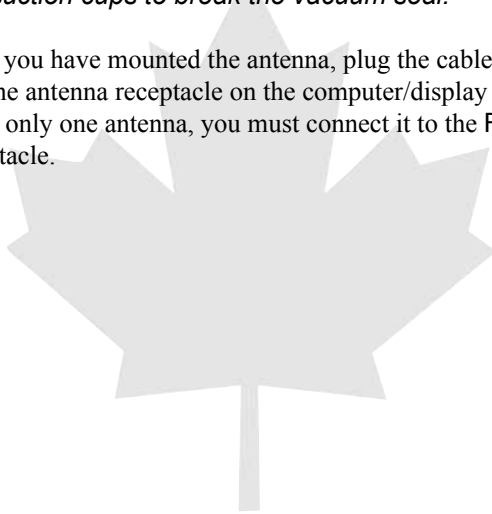

Figure 2.3c Orientation of the antenna to the target vehicle.

Point the antenna so it is aimed straight down the road and parallel with the ground. An officer must correlate the patrol vehicle speed with the speedometer in the police vehicle. Any significant deviation in the antenna will cause the patrol vehicle speed to be lowered and the difference added to the target speed window.

- • *Use only the mounting hardware provided. Damage to the antenna housing can occur if you use incorrect fasteners. The radar antenna should be mounted in a safe manner with either hardware provided with the unit or developed for use with the equipment by the Police Service.*
- *To reduce interference, position the antenna away from the patrol vehicle's display, fans, engine, and the Genesis-II Select Directional computer unit.*
- *When removing the bracket, use the tabs on the suction cups to break the vacuum seal.*

After you have mounted the antenna, plug the cable into the antenna and the antenna receptacle on the computer/display unit. If you are using only one antenna, you must connect it to the **FRONT** antenna receptacle.



## **2.4 Installation Check**

After you install the components, for safety, double-check to ensure all components are secure. Then check for potential interference from sources such as the air conditioner/heater fan.

1. With all other vehicle accessories off, turn on the heater/air conditioner fan.
2. Power up by pressing the **PWR** button on the hand-held remote and select the front antenna by pressing the **FRONT** button.
3. Cycle through the fan's low to high settings.
4. If the unit displays a reading, reposition the antenna to eliminate it. Often, the far-left corner of the front windshield is an interference-free zone where you can place an antenna.
5. Repeat this process for the rear antenna.

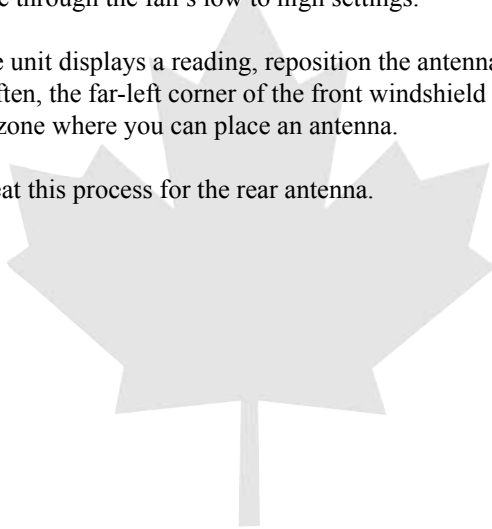

### **3. Operating the *Genesis-II Select Directional***

After you test and confirm that the unit is properly installed, it is ready for use.

#### **3.1 Power**

The PWR button on the hand-held remote turns the *Genesis-II Select Directional* on and off. After you press the PWR button, the display illuminates and the computer checks the circuitry. If the power-up checks pass, the computer displays TEST PASS in the MODE window. If the power-up checks fail, a system error message (SYS) will display in the MODE window and the unit will not respond to any control except the PWR button to power down. Turn the unit off then back on. If the error message persists, remove the unit from service and contact the Decatur Electronics Repair Department.

➤ *When the Genesis-II Select Directional is powered down, it stores the current settings. These settings are restored the next time you power up the unit.*

### 3.2 Front and Rear Antenna

At power up, the *Genesis-II Select Directional* antennas are in standby mode. (Standby mode is when the antenna is not transmitting.) If no antenna is connected to the unit, the FRONT and REAR lights cycle on and off and Ant? displays in the MODE window.



Figure 3.2a If no antenna is connected, Ant? displays.

The radar unit *will not* begin transmitting until you press an antenna button. The antenna (ANT) buttons, up arrow (FRONT) and down arrow (REAR), on the hand-held remote activate and deactivate the antennas. The FRONT or REAR light will illuminate when the antenna is transmitting.



Figure 3.2b When the FRONT light illuminates, the FRONT antenna is transmitting.

To *discontinue* transmitting press the ANT button matching the

active antenna.

The *Genesis-II Select Directional* has three main operating modes: Stationary, Moving Mode Opposite Direction, and Moving Mode Same Direction.

### 3.3 Stationary Mode

You can use Stationary Mode to monitor traffic that is moving toward or away from the parked patrol vehicle. You can also select a specific direction of traffic (towards or away) to monitor.

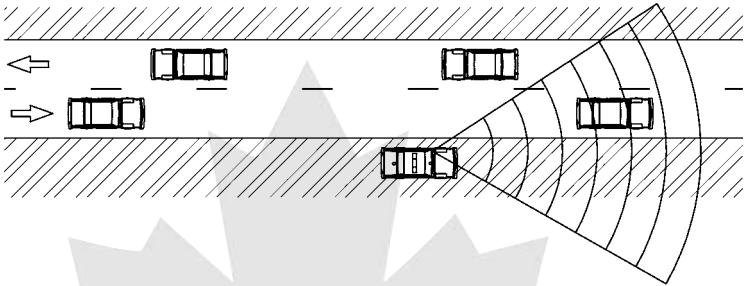

Figure 3.3a Tracking a vehicle moving AWAY from a stationary patrol car using the FRONT antenna.

There are three selections for stationary mode;

- Stationary Both (Tracks vehicles moving towards or away from the patrol vehicle)
- Stationary Towards (Only tracks vehicles coming towards the patrol vehicle)
- Stationary Away (Only tracks vehicles moving away from the patrol vehicle)

To select a Stationary Mode of operation, press and hold the MODE button for two seconds. The “Stationary Both” mode will be represented by two arrows on the left (one pointing up, one pointing down) and a solid line on the right representing a parked patrol car. When targets are measured, the letter “T” or “A” will be displayed along side of the solid line to indicate the target is moving TOWARDS or AWAY from the patrol car.



Figure 3.3b Stationary Both Mode

➤ *In order to select the “Stationary Towards” or “Stationary Away” modes, one of the antennas must be activated.*

Detected target speeds will display in the TARGET window. The PATROL window will always remain blank while in this mode.

After the “Stationary Both” mode has been selected, briefly press and release the MODE button a second time to select the “Stationary Towards” mode. Pressing and releasing the MODE button a third time will select the “Stationary Away” mode. Pressing and releasing the MODE button a fourth time will cycle to the moving opposite mode of operation.

When the radar is toggled into the “Stationary Towards” mode, a “T” will briefly be displayed along side of the solid line on the right. When the “T” is cleared, an arrow will be displayed that represents the direction of travel in which the radar will search. (When using the FRONT antenna, targets moving towards the patrol will be represented by an arrow on the left pointing down. An arrow will be pointing up when the REAR antenna is selected.) Once a solid target is acquired, the letter “T” will again appear.



Figure 3.3c Initially the letter “T” will indicate the Stationary Towards Mode has been selected. The “T” will also appear when a target is acquired.

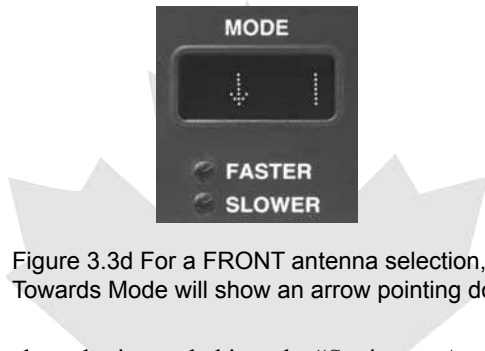

Figure 3.3d For a FRONT antenna selection, the Stationary Towards Mode will show an arrow pointing down.

When the radar is toggled into the “Stationary Away” mode, an “A” will briefly be displayed along side of the solid line on the right. Once the “A” is cleared, an arrow pointed in the appropriate direction (based on the antenna selection) will be displayed to indicate the direction of the targets moving AWAY from the patrol car. Once a solid target is acquired, the letter “A” will again appear.



Figure 3.3e Initially, the letter “A” will indicate the Stationary Away Mode has been selected. The “A” will also appear when a target is acquired.



Figure 3.3f For a FRONT antenna selection, the Stationary Away Mode will show an arrow pointing up.

Detected target speeds will display in the TARGET window. The PATROL window will always remain blank while in all of the stationary modes.



**WARNING**

- *When operating with the Directional Antenna, be sure the antenna facing forward is connected into the “FRONT” antenna port. If using dual antennas, the antenna facing the rear should be connected into the “REAR” antenna port.*

### 3.4 Moving Mode Opposite Direction

Use the *Genesis-II Select Directional* in the Moving Mode Opposite Direction setting to display the speed of a target moving toward or away from the moving patrol vehicle. These targets will be moving towards the patrol vehicle (using the front antenna) or away from the patrol vehicle (using the rear antenna).

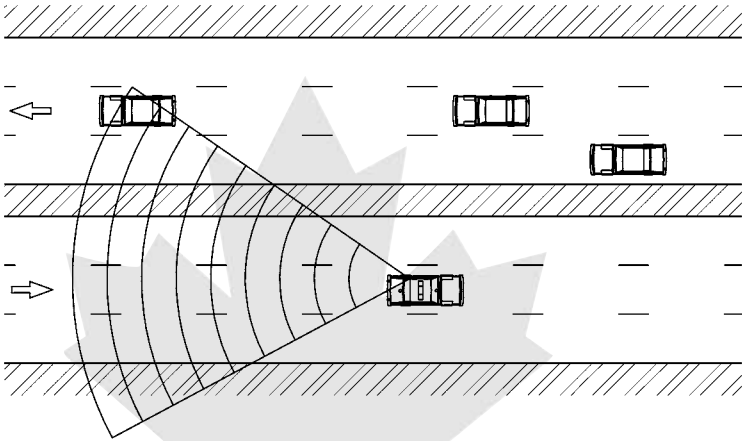

Figure 3.4a A patrol vehicle that is tracking a target vehicle with the rear antenna while traveling with the radar unit in Moving Mode Opposite Direction.

To select Moving Mode Opposite Direction, press the MODE button until the MODE window displays a down arrow on the left and an up arrow on the right. The down arrow indicates the target's travel direction. The up arrow indicates the patrol vehicle's travel direction.



Figure 3.4b The MODE window with Moving Mode Opposite Direction arrows.

In this mode, the *Genesis-II Select Directional* simultaneously processes and displays the patrol and target vehicle speeds.

Detected target speeds will appear in the TARGET window. When no targets are present, the TARGET window will be blank. Patrol speeds will display in the PATROL window while the patrol vehicle is moving.

### 3.5 Moving Mode Same Direction

To display the speed of targets traveling the same direction as the patrol vehicle, use the Moving Mode Same Direction setting.

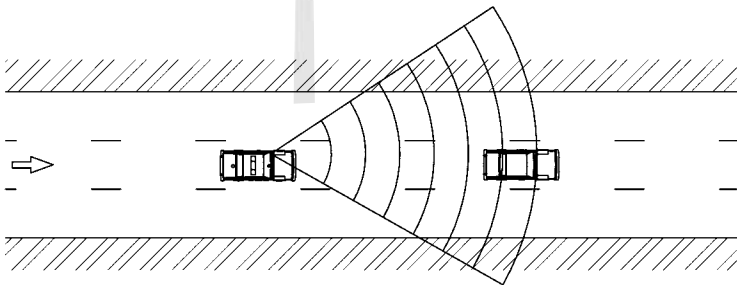

Figure 3.5a A patrol car tracking a target using the Moving Mode Same Direction setting.

To select this mode, press and release the MODE button until the

MODE window shows two upward pointing arrows.



Figure 3.5b The MODE window when the unit is in Moving Mode Same Direction.

Unlike conventional moving radars, the operator is not required to choose a “Faster or Slower” setting when measuring same lane targets. The *Genesis-II Select Directional* chooses the correct setting automatically.



**WARNING**

- *When operating with the Directional Antenna, be sure the antenna facing forward is connected into the “FRONT” antenna port. If using dual antennas, the antenna facing the rear should be connected into the “REAR” antenna port.*

### 3.6 Faster Mode

The *FAST* button<sup>1</sup> controls the Faster Mode feature that modifies the operation of the Stationary and Moving Mode Opposite Direction modes.

The Faster light illuminates when you press and hold the *FAST* button on the hand-held remote. (The unit will remain in Faster Mode for two seconds after you release the *FAST* button.)

When activated, the system switches from processing the speed of the strongest target to processing the next strongest target going faster than the strongest. In the figure below, the 99 km/h vehicle is the strongest target if the *FAST* button is activated, then the next stronger faster target, namely the passenger vehicle at 123 km/h will be displayed.

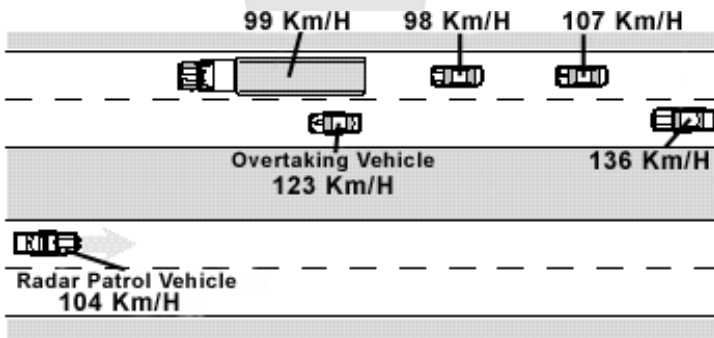

Figure 3.6 Evaluating multiple targets in Faster Mode.



*When in Stationary Mode, it is possible that the Faster vehicle is not traveling in the same direction as the Strongest vehicle.*

<sup>1</sup>The Genesis II Directional may be ordered with a different faster feature. When you press the *FAST* button, the strongest target displays in the *TARGET* window, the next strongest target speed going faster than the strongest target displays in the *LOCKED* window.

### 3.7 Lock a Speed

The LOCK button transfers the target speed in the TARGET window to the LOCKED window. After locking the speed, the radar unit continues to process speeds and display target speeds in the TARGET window. If the target locked was a speed of a motor vehicle clocked using the FAST function, that speed will be displayed in the locked window and the radar unit will then revert to monitoring and displaying the speeds of the strongest target. This will form part of the tracking history, because the strongest target all be it lower than the locked speed will be representative of the medium flow and you will have a tracking history/visual observation of the faster target closing in on the slower motor vehicle. Refer to diagram 3.6. This lets you continue to track the history of the target.

Clear a locked speed one of the following ways:

- Press the LOCK button when an antenna is transmitting and no target is present.
- Change the operating mode.
- Turn the antenna off then on again.
- When the antenna is off press LOCK button.
- Turn the unit off then on again (not recommended).
- *The locked speed will remain as tracking history when you change a dual-antenna transmission status from front to rear or rear to front.*
- *You may use the lock feature even when the radar is in Faster mode.*

### 3.8 Range Setting

You can adjust the range (sensitivity) of the *Genesis-II Select Directional* in each of the main operating modes independently;

Moving Opposite Mode  
Moving Same Lane Mode  
Stationary Modes

The *Genesis-II Select Directional* can track the speed of targets that exceed about 1 km when the unit is set at maximum range. The five LED lights above the word RANGE indicate the target-acquisition range.

Press the negative (-) or positive (+) side of the RANGE button to decrease or increase the range setting. The range lights progressively illuminate as you increase the distance. When all lights are on, the unit is in maximum range. Initially, you will want to start with maximum range, then decrease the range setting until you obtain a desired range. For example, an officer may wish to reduce the range setting when operating within a city environment.

The last range setting for each operating mode will be remembered when the unit is powered off and back on for continued use.

### 3.9 Stopwatch Operational Mode

You can use the *Genesis-II Select Directional* to calculate target speeds without transmitting radar by using the stopwatch mode. The stopwatch mode relies on the time / distance formula to calculate target speeds by measuring the amount of time a vehicle takes to travel a known distance.

$$SPEED = \frac{DISTANCE \text{ (in kilometers)}}{TIME \text{ (in hours)}}$$

To place the radar into stopwatch mode, first ensure that no antenna is currently selected, then press and hold the OPTN button for two seconds. The MODE window should display “StpW” to indicate you have activated the stopwatch functions.



Figure 3-9a The Mode Window will display “StpW” whenever the *Genesis-II Select Directional* is operating in the Stopwatch Mode.

The three numeric windows are used to display time, distance, and speed.

TARGET WINDOW:	Calculated Speed in km/h
LOCKED WINDOW:	Time in Tenths of Seconds
PATROL WINDOW:	Distance in Metres

Example:

96 km/h

150 Tenth Second Increments (15.0 Seconds) or .00416 hrs. 400 m or .4 km

To make use of the stopwatch mode, you need to have a road surface that is marked with known distance intervals, or you will need to

independently make a measurement between two visible points on the road in which you can time vehicles passing between those points (for example, a bridge underpass and a road sign) with some precise distance measuring equipment.

Once you have an established measurement area, use the “+” or “-” side of the **RANGE** button to enter the distance of the measurement area in meters. Quickly press and release one side of the **RANGE** button to cycle through single units. Hold the button down to begin cycling by tens then hundreds.

When the correct distance is set, you can time vehicles as they cross between the markers in your measurement area. Use the **LOCK** button to start and stop the timer. The time will be counted and displayed in the **LOCKED** window. Each sequential number represents a tenth of a second (there is no decimal point displayed between the right two digits). For example 150 represents 15.0 seconds.

After you have started and stopped the timer, a calculated speed will be displayed in the **TARGET** window. The speed shown will be in km/h.

The accuracy of the stopwatch mode will be limited by the precision in which the distance measurement was made and the precision in which the timer start and stop was activated. In general, to increase the accuracy of the measurement, use a longer measurement area.

Press the **MODE** button to exit the Stopwatch mode.

[If km/h units have been selected in the radar's setup menu, then the distance units will be in meters and the speed shown will be in km/h units.]

## 4. Computer/Display Unit

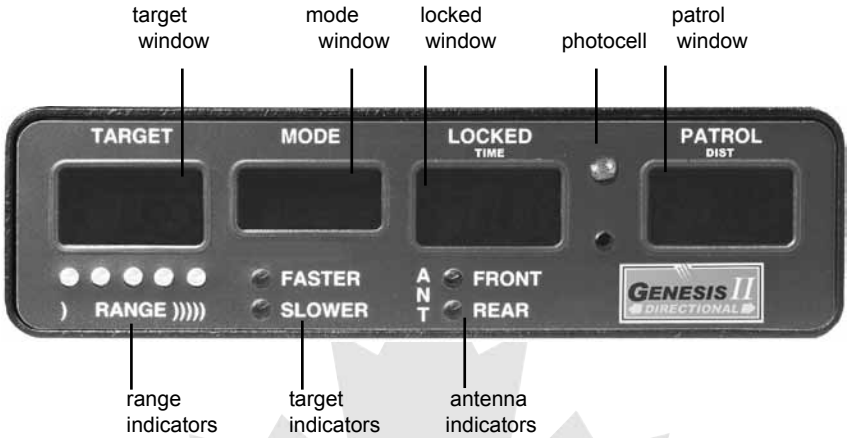

Figure 4a The *Genesis-II Select Directional* display unit (front).

The *Genesis-II Select Directional* display faceplate contains a photocell that automatically dims the display at night for less glare and makes the display brighter in daylight conditions, so you can easily read the display windows.



Figure 4b The *Genesis-II Select Directional* computer unit (back).

## 4.1 Display Windows

### TARGET

The TARGET window displays target speeds and is blank when no target is present.

### MODE

The MODE window displays the mode of operation (Stationary, Moving Mode Opposite Direction, or Moving Mode Same Direction) except during power up, self-test or when an error occurs. When an error occurs, one of the following appears in the MODE window:

- LowV – low voltage
- RFI – radio frequency interference
- SYS – system failure
- RMT? – disconnected hand-held remote
- ANT? - disconnected antenna

### LOCKED

When you press the LOCK button, the LOCKED window holds and displays the target speed that was in the TARGET window.

### PATROL

The PATROL window displays the patrol speed. The window is blank when the radar unit is in Stationary Mode or when the vehicle is traveling below the minimum patrol speed.

## 4.2 Lights

### RANGE

The range scale indicates the sensitivity setting (or the target-acquisition distance). The range can be set independently for each main operating mode.



Figure 4.2a The RANGE lights.

### FASTER

The Faster light illuminates when you press and hold the *FAST* button to activate Faster Mode.



Figure 4.2b The FASTER light.

## ANT FRONT and REAR

The ANT FRONT and REAR indicator lights show which antenna is transmitting. In standby mode, neither light is on and neither antenna is transmitting.



Figure 4.2c The FRONT and REAR antenna lights.

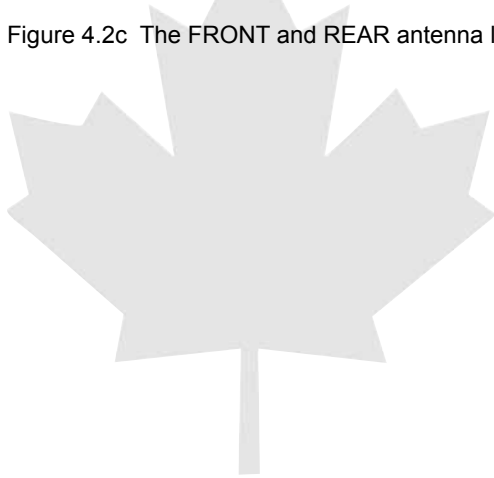

## **5. Antennas**

The *Genesis-II Select Directional* K- band antennas are incredibly strong, yet compact and light weight. The antennas are interchangeable. The cables and connectors are also interchangeable and work with either antenna.



Figure 5 Antenna for the *Genesis-II Select Directional*.

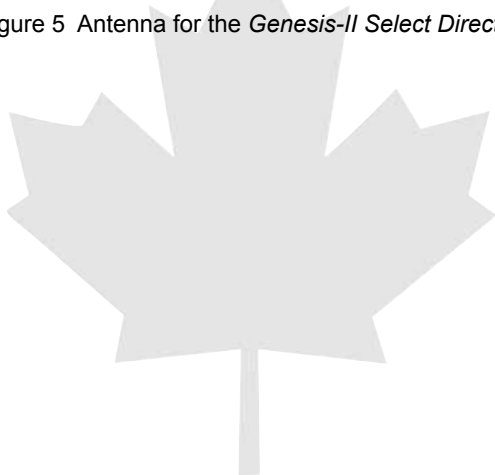

## 6. Hand-Held Remote Control

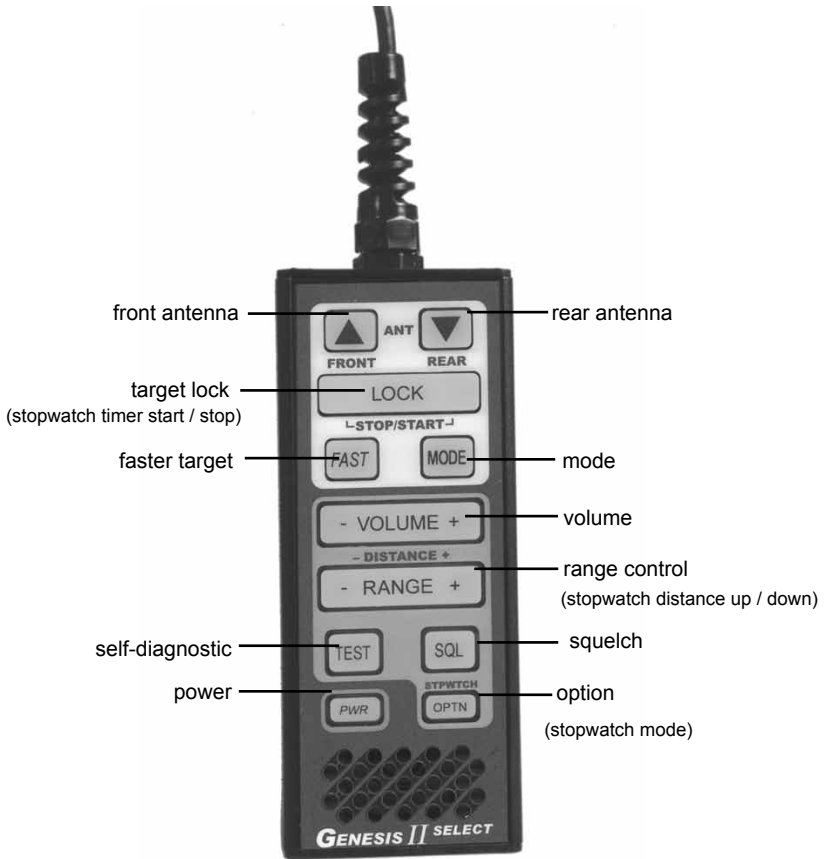

Figure 6 The hand-held remote control unit.

➤ *If the hand-held remote is removed during operation, RMT? appears in the MODE window, and the will stay on until the remote is plugged back in. If RMT? is displayed, the unit will become inoperative and no speed readings can be taken.*

## 6.1 Control Buttons

### Power (PWR)

The PWR button powers the *Genesis-II Select Directional* on and off.

### Option (OPTN)

#### City/Highway

The City/Highway option helps reduce shadowing by setting a different minimum patrol speed for city and highway speed conditions. This option works only while the unit is set in a Moving Mode. Patrol speed shadowing cannot occur regardless of whether the member selects the City or Highway option if the Genesis II Select is connected to the Decatur V.I.P. interface.

When you press the OPTN button, CITY temporarily appears in the MODE window, and the unit tracks patrol speeds only as low as 8 km/h. Press OPTN again to set the unit to Highway Mode. HWY temporarily appears in the MODE window, and the unit tracks patrol speeds no lower than 32 km/h. The radar unit will power up with the settings you select. The main function of the OPTN button is toggling between City and Highway Modes, but other options are available.

### Stopwatch Mode

To place the *Genesis-II Select Directional* into the Stopwatch operational mode, press and hold the OPTN button for two seconds. The letters StpW will appear in the MODE window. Press the OPTN button again to exit this mode. See section 3.9 for a full description of the Stopwatch Mode.

## Patrol Speed Lock, Recall, and Blanking

This feature comes standard with the Genesis II Directional and will enable the patrol officer to lock a target speed which will then become displayed in the locked window, while remembering internally what the patrol speed was at the time the speed was locked. The Genesis II Directional will, as long as the antenna remains activated, continue to track both the speed of the target in the target window and the patrol vehicle speed in the patrol window.

1. When the antenna is turned off by the operator, the locked patrol speed will appear in the patrol window. This locked patrol speed will be reflective of the speed of the police platform at the time initial target reading was locked.
2. To blank the patrol speed, press the OPTN button. Then press the OPTN button again to recall it.
3. To permanently remove the locked patrol speed, reactivate the antenna by turning it on.

## Test (TEST)

Pressing the TEST button starts an extensive self test of the radar unit's circuitry. During self test, the system will not power down until the test is complete. If the self test fails, the SYS message will appear in the MODE window. For more information on tests, see section 9 Field Tests.

Pressing and holding the test button activates the menu feature. This feature allows the operator to adjust some of the settings of the radar. See Appendix B for more information.

## Squelch (SQL)

The SQL button lets you select the type of Doppler audio you hear. In squelch mode, the sound is only the Doppler tone for the currently displayed target. In unsquelch mode, the unit sends out all Doppler tones received by the antenna—patrol vehicles, targets,

interference, and noise. You typically use unsquelched audio when you listen for interference.

### Range (– RANGE +)

The RANGE button on the hand-held remote regulates the maximum target-acquisition distance. You press the negative (–) or positive (+) side of the RANGE button to decrease and increase the target acquisition distance. When operating in the Stopwatch Mode, the range button is used to cycle through distance units in yards or meters.

### Volume (– VOLUME +)

The 8-step volume control regulates the Doppler audio and system status tone (beep) volume. Press the negative (–) or positive (+) side of the VOLUME button to decrease and increase the volume level. If your radar unit has audio settings that include muted or a numerical value of zero, it is imperative that your volume never be set at either of those settings as the Doppler audio is a mandatory requirement for a valid tracking history and the selection made is an operator preference. Refer to 9.3, item 4.

### Fast (*FAST*)

Use the *FAST* button to control the Faster Mode feature when you are evaluating multiple targets, either moving opposite or stationary modes, also use the *FAST* button to switch to between Faster and Slower settings when operating in the Moving Same Direction Mode.

## Mode (MODE)

The MODE button switches between the three operating modes: Stationary Mode, Moving Mode Opposite Direction, and Moving Mode Same Direction.

## Lock (LOCK)

The LOCK button transfers the target speed in the TARGET window to the LOCKED window. After locking the speed, the system continues to process and display target speeds in the TARGET window, so you can continue to track the history of the target speed. If you have the Patrol Speed Lock, Recall, and Blanking option, pressing the LOCK button locks both the target and patrol speed.

## Antenna (ANT) FRONT and REAR

The antenna (ANT) up arrow (FRONT) and down arrow (REAR) buttons activate and deactivate the front and rear antenna. An antenna must be activated to track a target speed.

## **7. Communication System Controls**

You can configure the *Genesis-II Select Directional* through the serial communication (COM) port on the rear panel to communicate with PCs, speed signs, and in-car video systems, such as the Decatur Electronics *Gemini™* in-car video system. Please note, additional video equipment may be necessary for proper interface. The communication cable does not come with your order and can be purchased separately from Decatur Electronics. See Appendix A for more details on the serial communication port configuration.



## 8. Performance Tips

Understanding potential radar interference and what to do when it occurs can greatly increase the radar's performance.

### 8.1 How Radar Works

Determining a vehicle's speed, begins with the radar antenna transmitting and directing a beam of microwave energy (radio waves) at an approaching (or receding) target vehicle. When energy from this beam strikes a moving vehicle, a small amount of the beam is reflected back to the antenna. The reflected signal frequency shifts by an amount proportional to the speed of the target vehicle. This is known as the Doppler Principle. The radar device then determines the target vehicle speed from the difference in frequency between the reflected and transmitted signal.

### 8.2 Interference Sources and Remedies

When properly deployed and operated, Doppler radar technology is extremely accurate and reliable. However, variations in the environment can cause situations and circumstances, which can cause spurious (erratic and unusually low or high) speeds to display. Signs that a speed is spurious can include the following characteristics:

- A reading appears when no target vehicle is in the operational range of the antenna.
- A target vehicle entering the operational range overrides the interference signal, causing the display speed to change suddenly to the vehicle's speed. This comment applies to paragraphs 8.2.2 through 8.2.10.
- The Doppler tone is corrupted with noise.
- Speeds are irregular and do not provide a valid reading.
- Erroneous speeds appear to track with the engine speeds.

Interference regardless of the source is neither additive or subtractive of a valid target reading. Interference will not impact on the accuracy

of the radar unit, but it will impact on the operational range. If a member establishes a solid tracking history, as referred to in section 9.3, it can be established that interference was not present at the time of the speed reading.

### 8.2.1 Angular Interference (Cosine Effect)

The cosine effect causes the radar unit to display a speed, which is lower than the actual vehicle speed. This condition exists when the target vehicle's path is not parallel to the antenna, including conditions such as the vehicle traveling on a curve or a hill.

As the angle between the beam of the antenna and the target vehicle increases, the displayed speed decreases. Ideally, an angle of zero (0) degrees is preferable, because the displayed speed is the actual target vehicle speed. However, in all uses of police radar, the radar device is always at a slight angle to the target vehicle to avoid collisions.

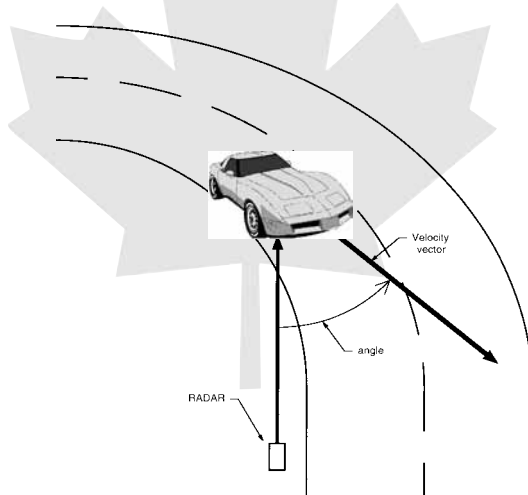

Figure 8.2.1 An angle between the antenna and the target vehicle causes the cosine effect.

The following table shows the effect that an increasing angle has on a displayed speed.

Actual speed:	Horizontal angle degrees:										
	0°	1°	3°	5°	10°	15°	20°	30°	45°	60°	90°
50 km/h	50	49	49	49	49	48	46	43	35	25	0
65 km/h	65	64	64	64	64	62	61	56	45	32	0
80 km/h	80	79	79	79	79	77	74	69	56	40	0
90 km/h	90	89	89	89	88	86	84	77	63	45	0
100 km/h	100	99	99	99	98	96	93	86	70	50	0
110 km/h	110	109	109	109	108	106	103	95	77	55	0

Table 8.2.1 Actual and displayed speeds at different antenna-to-target angles.

Small angles (less than 10°) have little effect on a target reading. As the angle increases, the displayed speed decreases. At 90°, the target speed is 0 km/h—grossly incorrect. Cosign Effect in stationary mode will always result in a target speed being displayed that is less than the actual speed of the moving motor vehicle, which will always be advantageous to the motorist.

### 8.2.2 Fan Interference

Fan interference is the most common form of interference that you are likely to experience. It is caused when the radar measures the speed of the vehicle blower fan. Changing the fan speed causes a proportional change in the display speed. To correct this, relocate the radar antenna so it does not display spurious speeds or turn off the fan motor.



*Fan interference may occur in same directional operation; however, if the member conducts a target vehicle speed discrimination test, as recommended for same direction operation, it will ensure that fan interference is never the source of a target reading. Please refer to 9.3 Tracking History. This target discrimination test is required for all moving radar units in same direction mode. In addition, to eliminate fan interference as the source of the reading in units that do not have “Direction Sensing”, which is a feature of the Genesis*

*II Directional, the target vehicle speed discrimination test will confirm that the member is in the correct same direction mode.*

### 8.2.3 Batching

In past years, some radar devices occasionally could not correctly process speeds when the patrol vehicle was accelerating or decelerating at unusually high rates. In these cases, radar devices used an earlier speed to calculate the target speed, rather than the current speed. The radar will display an incorrect target speed, because it is using an incorrect patrol speed. With the DSP algorithms the *Genesis-II Select Directional* uses, this error will not occur.

### 8.2.4 Electromagnetic Interference (EMI)

Operating electric motors can produce EMI. EMI from power seats or windshield wipers can also produce spurious target speeds. To correct this type of interference, simply turn off its source.

### 8.2.5 Feedback Interference

When radar is directed at computer screens, streetlights, and other electronic devices, it can display spurious speeds. To correct this type of interference, relocate the radar antenna.

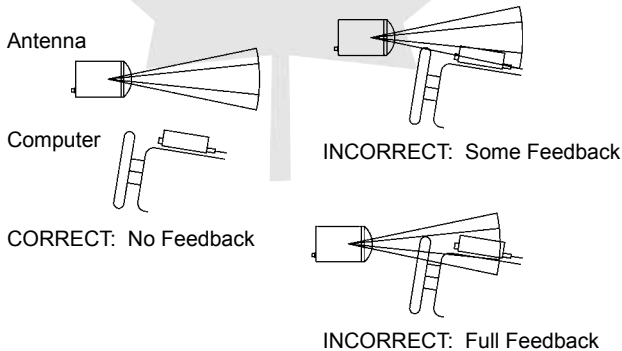

Figure 8.2.5 Correcting feedback interference.

### 8.2.6 Multi-Path Beam Cancellation

If multi-path beam cancellation occurs, the target vehicle speed sporadically blinks and reappears at semi-random intervals. This type of interference occurs when the radar loses track of a target vehicle, because the target is reflecting two or more signals, which are interfering with each other. The *Genesis-II Select Directional* is immune to multi-path cancellation.

### 8.2.7 Patrol Harmonics

In all police radar, when a patrol vehicle passes a large, stationary object such as a road sign, building, or overpass, the return signal can briefly overload the processing circuitry.

➤ The *Genesis-II Select Directional* detects this condition and will not display speeds which are generated by this overloading.

Targets traveling at speeds which are close to the patrol speed can also mimic this condition and will be rejected. The target window will show an “\_H\_” indicating that it is a patrol harmonic. To process this type of target, simply increase or decrease your patrol speed by at least 3 km/h.

### 8.2.8 Radio Frequency Interference (RFI)

The system can inadvertently process radio energy as Doppler speeds, including that from police radios, airport radar, microwave transmission towers, CB radio transmitters, and AM/FM transmission towers. For this type of interference to occur, the radar unit must be operating very close to the radio transmitter.

The *Genesis-II Select Directional* contains an RFI detection circuit that detects excess radio frequency energy. When stray radio frequency energy reaches an excessive level, the system displays the RFI message and stops processing and displaying speeds. The system resumes normal operation when the RFI condition no longer exists. At that time, any locked speeds will display again.

## 8.2.9 Shadowing

In Moving mode, the radar processes two speeds—patrol and closing (target). The stronger of the two, the patrol speed, is created when the radar beam reflects from passing stationary objects, such as the pavement or terrain the vehicle is traveling on.. However, some situations cause return signals to be larger than the reflection from the ground, such as when the patrol vehicle is rapidly overtaking a slow-moving 18-wheeler. Given a choice between reading passing ground clutter or the large return signal generated by the vertical expanse of the truck's trailer, the radar might ignore the ground speed and lock onto the stronger return signal. Rather than receiving a true patrol speed, the radar reads the differential speed between the vehicle and the 18-wheeler. The computer then subtracts this artificially low speed from the closing speed and assigns a higher speed to the target. The shadowing error is easy to recognize, because the radar patrol speed and the speedometer reading will vary significantly. The target speed in this instance also will vary considerably from your visual estimation. The correct City/Highway setting helps to minimize this effect. A valid tracking history, as referred to in Sections 9.3, will confirm that patrol speed shadowing was not present. Furthermore, after exhaustive field tests with a Genesis II Select connected to a VIP interface, it has been impossible to create a patrol speed shadowing event. Notwithstanding these field tests, the requirement for a correlation between the patrol vehicle speed displayed on the radar and the actual patrol speed of the police vehicle is mandatory. Please refer to 9.3.

➤ *The Genesis-II Select Directional usually recognizes and ignores shadowing. On the rare occasion that it appears, turning the antenna on and off usually quickly remedies shadowing.*

With regard to this phenomenon, it is important that the operator has obtained a solid tracking history which includes that there be a correlation between the patrol speed displayed on the radar and the patrol speed displayed on the police platform. By ensuring that correlation exists, the operator can be satisfied that the patrol speed shadowing did not occur.

In addition, if your *Genesis-II Select Directional* is equipped with the VIP (Vehicle Interface Portal) interface there is no possibility of obtaining an artificially low or high patrol speed, because the VIP is integrated to the speedometer and the electronically components of the police vehicle. Field tests under every possibly situation have been attempted and every effort has been made to create a patrol speed shadowing situation with a VIP unit connected, and it has been found to be impossible to create that phenomenon. Notwithstanding these rigid tests it is still a mandatory requirement that the officer have an actual correlation of his or her patrol speed and the patrol speed displayed on the radar unit prior to any enforcement action being taken.

Listed below are the components of a tracking history:

1. A Visual Observation of an approaching or receding Motor Vehicle that appears to be in excess of the posted speed limit in the area. Generally, skilled officers are able to estimate the speeds of moving motor vehicles within plus or minus 5 km/h per hour of the actual speed. This is an acquired skill that is taught in the basic operator's course.
2. Having made the visual observation, the radar unit will be placed in the operational mode, selecting and activating the appropriate antenna.
3. The officer then must determine or confirm the correlation between the patrol speed of the police vehicle and the patrol speed displayed on the radar unit. This correlation should be consistent with the results noted while conducting the road test in 9.2.
4. Note, that the target speed displayed on the radar unit is consistent and confirms the officers initial observations, and that the audio tracking tone emitted by the radar unit is consistent with the visual observations and the target speed displayed. Absent of any one of the above tracking history components and NO ENFORCEMENT ACTION shall be undertaken.

## **8.2.10 Vehicle Ignition Interference**

The *Genesis-II Select Directional* has been designed to operate from the vehicle's cigarette lighter receptacle. However, some vehicles exhibit excessive alternator noise at the lighter receptacle. In these rare cases, the radar can exhibit erratic readings, especially when the vehicle's electrical system is operated under heavy load. Wiring an accessory outlet directly to the battery minimizes the effect.

Proper installation and mounting of the radar as described in Section 2.3 and 2.4 would have identified vehicle ignition interference and would be addressed prior to the radar unit being placed in service in the police vehicle. If you suspect your vehicle's electrical system, contact Decatur Electronics' Customer Service Department for more information.



## 9. Field Tests

You can do the following tests to verify the accuracy of the *Genesis-II Select Directional*.

### 9.1 Operator-Requested Self Test

Pressing the *TEST* button initiates a comprehensive system self test, which checks the numeric displays and runs a target and patrol speed simulation. The *Genesis-II Select Directional* will not power down during a self test and checks the following:

**Display Test** — The display test allows the operator to visually verify that the digit segments and status LED lights are working correctly and that none of the pixels in the number segments are burned out.

**Circuitry Test** — The system checks the internal circuitry. If the unit passes all internal checks, the messages ROM PASS, RAM PASS, and DSP PASS or FAIL (if a test fails) display in the MODE window.

**Speed Simulation Test** — The *Genesis-II Select Directional* verifies the speed accuracy using synthesized Doppler frequencies corresponding to a series of four simulated speeds: 25, 50, 75, and 100 km/h.

### 9.2 Road Test

After the radar unit has passed the self test the operator shall conduct a road test at the start and conclusion of his or her tour of duty and confirm the correlation that exists between the patrol vehicles speedometer and the patrol speed displayed on the radar unit. Generally, the correlation will be the same for both units and seldom beyond 3 km/h per hour. That difference if present is reflective of the under estimation of the speedometer in the police vehicle and NOT an indication of an inaccuracy with the radar unit.

If your *Genesis-II Select Directional* is configured as a dual antenna unit, the verification requirements will be met by the officer maintaining a stable patrol speed and toggling between the front and rear antenna at which time the patrol speeds for the front and rear antenna should be the same.

In addition to this road test, as part of the tracking history for any violation in which enforcement action is to be taken, it is a mandatory requirement that there be this correlation between the patrol speed of the police vehicle and the patrol speed displayed on the radar unit at that time. Without this correlation no enforcement action shall be taken.

*An incorrectly aimed antenna will cause the radar unit's patrol speed to be lower than the speedometer's speed.*

### 9.3 Tracking History

For each enforcement action taken by the police with respect to a speeding offence arising out of the use of this radar unit a tracking history must occur. The tracking history shall consist of:

1. A Visual Observation of an approaching or receding Motor Vehicle that appears to be in excess of the posted speed limit in the area. Generally, skilled officers are able to estimate the speeds of moving motor vehicles within plus or minus 5 km/h per hour of the actual speed. This is an acquired skill that is taught in the basic operator's course.
2. Having made the visual observation, the radar unit will be placed in the operational mode, selecting and activating the appropriate antenna.
3. The officer then must determine or confirm the correlation between the patrol speed of the police vehicle and the patrol speed displayed on the radar unit. This correlation should be consistent with the results noted while conducting the road test in 9.2.
4. Note that the target speed displayed on the radar unit is consistent and confirms the officer's initial observations, and that the audio tracking tone emitted by the radar unit is consistent with the visual observations and the target speed displayed.

5. Where a target speed is determined while in same direction mode, regardless of whether a VIP interface exists, the operating member must conduct a target vehicle discrimination test. For non-direction sensing units, it will confirm that the unit was being deployed in the correct same direction mode, and for all other radar units, it will confirm that there is no fan or spurious response.
6. Absence of any one of the above tracking history components and NO ENFORCEMENT ACTION shall be undertaken.

## **10. Care, Cleaning, and Storage**

- Avoid spilling food, beverages, and other liquids and substances on the radar device.
- When you are not using or transporting the device, store it in its original packaging.
- To clean the radar device, dust it with a soft clean cloth, which is free of cleaning solutions.
- The *Genesis-II Select Directional* can withstand temperature variations, however, only the antenna is weather resistant.
- Insert and remove the connectors by following the correct connect and disconnect procedures.

## 11. Specifications

### 11.1 Mechanical

<b>Display Unit</b>	
Dimensions	5.25 in x 1.45 in x 1.10 in 13.33 cm x 3.68 cm x 2.79 cm
Weight	5.90 oz 0.17 kg
<b>Computer Unit</b>	
Dimensions	5.25 in x 1.45 in x 3.00 in 13.33 cm x 3.68 cm x 7.63 cm
Weight	14.5 oz 0.41 kg
<b>Hand-Held Remote</b>	
Dimensions	5.00 in x 1.20 in x 2.10 in 12.70 cm x 3.04 cm x 5.33 cm
Weight	9.10 oz 0.26 kg
<b>K-Band Directional Antenna</b>	
Dimensions	4.15 in x 3.00 in 10.54 cm x 7.62 cm
Weight	13.25 oz 0.37 kg

## 11.2 Antenna

<b>K-Band Directional</b>	
IACP type	IV
Nominal transmission frequency	24.150 GHz ± 50 MHz
Nominal horizontal beamwidth	12°
Polarization	Circular
Nominal microwave power output	7mW
Maximum aperture power density	≤ 1mW/cm <sup>2</sup>

## 11.3 Environment

<b>Ambient operating temperatures</b>	-22°F to 158°F -30°C to +70°C
<b>Maximum humidity</b>	90% relative humidity at 98.6°F (37°C)

## 11.4 Power Consumption

<b>Supply voltage range</b>	10.8 to 16.5VDC with internal, resettable fuse
<b>Low voltage threshold</b>	10.8VDC with visual indicator
<b>Current draw with 13.6VDC applied in various modes:</b> (K-Band)	
Standby (antenna OFF)	0.35 amperes
Antenna ON, no targets displayed	0.50 amperes
Antenna ON, 55 target displayed	0.53 amperes
Antenna ON, 20 target, 35 patrol	0.55 amperes
Antenna OFF, segment check 888 888 888	0.60 amperes
Antenna ON, segment check 888 888 888	0.75 amperes

## 11.5 Accuracy

The speed calculations of any radar Decatur Electronics produces are 100% accurate. Their display precision is as follows:

+/- 1 Unit of Measure in Stationary, Non Directional Mode of Operation
+/- 1 Unit of Measure in Stationary, Directional Mode of Operation
+/- 1 Unit of Measure in Moving, Opposite Direction Mode of Operation
+/- 1 Unit of Measure in Moving, Same Direction, Non Directional Mode of Operation
+/- 1 Unit of Measure in Moving, Same Direction, Directional Mode of Operation

## 11.6 Speed Range

<b>Stationary Mode</b>	
Target	19 km/h - 337 km/h
<b>Moving Mode Opposite Direction</b>	
Patrol	Patrol with High-Speed Option
8 km/h - 161 km/h	16 km/h - 180 km/h
Target	
19 km/h - Closure of 337 km/h	
<b>Moving Mode Same Direction</b>	
Patrol	Patrol with High-Speed Option
32 km/h** - 160 km/h	32 km/h - 180 km/h
Slower Target	Slower Target with High-Speed Option
8 km/h - 120 km/h	8 km/h - 135 km/h
Faster Target	Faster Target with High-Speed Option
37 km/h - 281 km/h	37 km/h - 308 km/h
<p>The Moving Mode Same Direction target speed is computed as:</p> <p>when tracking a slower target    <math>TS = PS - SS</math>                      when tracking a faster target    <math>TS = PS + SS</math></p> <p>where</p> <p>TS = Target Speed                      PS = Patrol Speed</p> <p>This is done automatically by the directional sensing component of the Genesis II Directional.</p> <p>SS = Separation Speed — With the Genesis II Directional, the operator has the ability of selecting either 4 km/h, 8 km/h, or 12 km/h as the minimum speed separation that must exist before a target reading can be obtained. This is simply an officer preference and is often dictated by medium speed in a given area, volumes of traffic and a desire by the officer to be able to patrol at or reasonably close to the posted speed limit of the area. The maximum speed separation can not be greater than 75% of the patrol speed.</p>	

## 12. Legal Requirements

### 12.1 FCC Documents

FEDERAL COMMUNICATIONS  
COMMISSION  
WASHINGTON, D.C. 20554

GRANT OF EQUIPMENT  
AUTHORIZATION

Certification

Decatur Electronics Inc  
715 Bright Street  
Decatur, IL 62522  
United States

Date of Grant: 02/28/2000  
Application Dated: 12/21/1999

Attention: Randall Sanner , President

**NOT TRANSFERABLE**

EQUIPMENT AUTHORIZATION is hereby issued to the named GRANTEE,  
and is VALID ONLY for the equipment identified hereon for use under the  
Commission's Rules and Regulations listed below.

FCC IDENTIFIER:  
HTRCR-1KD

Name of Grantee:  
Decatur Electronics Inc

Equipment Class:  
Part 15 Field Disturbance Sensor

Notes:  
Traffic Safety Radar

## 12.2 Canadian Industry Certificate of Technical Acceptability



Industry  
Canada

Industrie  
Canada

No. ► 18276

### TECHNICAL ACCEPTANCE CERTIFICATE

### CERTIFICAT D'ACCEPTABILITÉ TECHNIQUE

CERTIFICATION No. No. DE CERTIFICATION	►	1270A-GVPD
ISSUED TO DÉLIVRÉ À	►	DECATUR ELECTRONICS INC.
TYPE OF EQUIPMENT GENRE DE MATÉRIEL	►	RADAR
TRADE NAME AND MODEL MARQUE ET MODELE	►	GENESIS II KD
FREQUENCY RANGE BANDE DE FRÉQUENCES	►	24.134 GHz
EMISSION DESIGNATION DESIGNATION D'ÉMISSION	►	3M00N0N
R.F. POWER RATING PUISSANCE NOMINALE H.F.	►	368.6 mWatt
CERTIFIED TO CERTIFIÉ SELON LE	►	SPECIFICATION      RSS210      ISSUE 5 CAHIER DES CHARGES      ÉDITION

#### FAMILY APPROVAL WITH GENESIS-VP DIRECTIONAL (CERTIFICATE NO.18062)

Certification of equipment means only that the equipment has met the requirements of the above noted specification. License applications, where applicable to use certified equipment, are acted on accordingly by the issuing office and will depend on the existing radio environment, service and location of operation.

This certificate is issued on condition that the holder complies and will continue to comply with the requirements of the radio standards specifications and procedures issued by the Department.

L'homologation de matériel terminal signifie seulement qu'il est conforme aux exigences du cahier des charges mentionné ci-dessus. Les demandes de licence, le cas échéant en vue de l'utilisation de matériel certifié seront traitées en conséquence par le bureau chargé de délivrer lesdites licences, en tenant compte du milieu radioélectrique ambiant, du service radio existant et de l'emplacement de la station.

Le présent certificat est délivré à condition que le détenteur se conforme et continue à se conformer aux cahiers des charges et procédures sur les normes radioélectriques publiées par le ministère.

ISSUED UNDER THE AUTHORITY OF MINISTER OF INDUSTRY  
DELIVRE AVEC L'AUTORISATION DU MINISTRE DES INDUSTRIE

DATE    **May 19, 2003**

FOR

DIRECTOR GENERAL  
SPECTRUM  
ENGINEERING  
BRANCH

DIRECTEUR GÉNÉRAL  
GÉNIE  
DU SPECTRE

Canada



American Telecommunications Certification Body Inc.  
6731 Whittier Ave, McLean, VA 22101

REF No. ▶ ATCB002080

**TECHNICAL ACCEPTANCE  
CERTIFICATE**

**CERTIFICAT D'ACCEPTABILITÉ  
TECHNIQUE**

CERTIFICATION No. No. DE CERTIFICATION	▶ 1270A-K1438			
ISSUED TO DÉLIVRÉ A	▶ Decatur Electronics, Inc 715 Bright Street Decatur, IL 62522 USA			
TYPE OF EQUIPMENT TYPE DE MATÉRIEL	▶ Radar Device, Field Disturbance Sensor			
TRADE NAME AND MODEL MARQUE ET MODELE	▶ Genesis II Select Ka-Band Genesis II Select Directional Ka-Band			
FREQUENCY RANGE BANDE DE FRÉQUENCES	▶ 35.4-35.6 GHz			
EMISSION DESIGNATION DESIGNATION D'ÉMISSION	▶ 60H0N0N			
R.F. POWER RATING PUISSANCE NOMINALE H.F.	▶ 128 dBuV @ 3 meters			
ANTENNA ANTENNE	▶ Internal			
TEST LABORATORY LABORATOIRE D'ESSAI	▶ University of Michigan / EECS 1301 Beal Avenue Ann Arbor, Michigan 48109-2122 USA		SITE NUMBER NUMÉRO DE SITE	▶ 2057
CERTIFIED TO CERTIFIÉ SELON LE	▶ SPECIFICATION CAHIER DES CHARGES		RSS-210	ISSUE 1 - 5 as Amended ÉDITION

Certification of equipment means only that the equipment has met the requirements of the above noted specification. License applications, where applicable to use certified equipment, are acted on accordingly by the issuing office and will depend on the existing radio environment, service and location of operation.

This certificate is issued on condition that the holder complies and will continue to comply with the requirements of the radio standards specifications and procedures issued by Industry Canada.

L'homologation de matériel terminal signifie seulement qu'il est conforme aux exigences du cahier des charges mentionné ci-dessus. Les demandes de licence, le cas échéant en vue de l'utilisation de matériel certifié seront traitées en conséquence par le bureau chargé de délivrer lesdites licences, en tenant compte du milieu radioélectrique ambiant, du service radio existant et de l'emplacement de la station.

Le présent certificat est délivré à condition que le détenteur se conforme et continue à se conformer aux cahiers des charges et procédures sur les normes radioélectriques publiées par l'industrie Canada.

DATE OF ISSUE: February 2, 2005

**William H. Graff**  
President and Director of Engineering

110504-10

## 12.3 Radar Case Law

See Appendix C for more information on the Offense of Speeding and Training Qualifications.

### 13. Frequently Asked Questions (FAQ)

- Q. My radar device will not power up. What should I do?
- A. Make sure the radar device is plugged into the power source and that the power source has power. Also, check to see if the LED light on the power plug is on and that the fuse in the power plug is working. If the unit still does not power up, contact Decatur Electronics.
- Q. My radar device has poor range. How can I remedy this?
- A. Make sure the range control is adjusted properly and verify that no obstructions are in front of the antenna. If the antenna still has poor range, increase the range (sensitivity) level. If this problem continues, contact Decatur Electronics.
- Q. Do the Decatur Electronics traffic safety radar devices interface with in-car video systems?
- A. Yes. Decatur's traffic safety radar devices will interface with various in-car video systems with an active communications (COM) port, including the Decatur Electronics *Gemini*™ in-car video system. Please call the Decatur Electronics sales staff to see which video systems will work with your Decatur radar device.
- Q. How often do I need to recertify my radar unit?
- A. In the past, the Federal Communications Commission (FCC) required that you check all devices with transmitters once a year to guarantee that they are transmitting within the allowed band. The FCC has since then dropped this requirement. Now, most states have set up their own standards to regulate the timing of radar certification. Because each state has different requirements, Decatur Electronics recommends that you check with your local department policy.

- Q. Does Decatur Electronics carry other law enforcement radar products?
- A. Yes, the **Genesis™** series of hand-held stationary radar guns, such as the **GHD™**, **Genesis-VP™**, **Genesis-VPD™** (*Directional*) and dash-mount radar systems.

- Q. Does Decatur Electronics have a sports radar gun?
- A. Decatur Electronics has developed a radar gun specifically for use in baseball and softball. We market this radar gun exclusively through the JUGS Company. Contact 800.547.6843, [www.thejugscompany.com](http://www.thejugscompany.com).

Decatur's **Prospeed™** model CR-1K sports radar works well for boat, personal watercraft and snowmobile racing. Contact Decatur Electronics for more information on this product.

- Q. Does Decatur Electronics make speed trailers or speed signs?
- A. Yes, Decatur has a variety of speed signs and radar/message trailers—the **OnSite™** series. Contact your Decatur sales representative for more information on these products.

- Q. What upgrades are available now for my **Genesis-II Directional**?

- A. Contact Decatur Electronics Sales Department 800.428.4315 for upgrade information.

- Q. SYS appears in the MODE window and nothing else works?

- A. If your unit has a system error, turn the unit off and on. If it still says SYS, contact Decatur Electronics.

## 14. Service

### 14.1 Warranty

#### **TWO-YEAR RADAR WARRANTY**

Decatur Electronics, Inc. guarantees the *Genesis-II Select Directional* to be free from defects in workmanship and material and to operate within specifications for a period of two years. During this period, Decatur Electronics will repair or replace, at its option, any component, found to be defective, without cost to the owner providing you return the unit to the factory or a Decatur authorized warranty service center.

The full warranty on parts and workmanship does not include normal wear and tear, crushing, dropping, fire, impact, immersion, damage from attempted repair, modifications by unauthorized service agents, or improper voltage and fusing (including removal of the power plug.)

For repairs, simply return the unit (transportation prepaid) directly to the factory or to a Decatur authorized warranty service center. Refer to section 14.2 Service Return Procedure.

#### **TWO-YEAR WARRANTY EXCEPTION**

If you purchased the radar unit under a special buying program, such as a state purchase contract, etc., the above warranty may not apply. Please refer to the buying program contract for the appropriate warranty terms or contact Decatur Electronics.

If you are interested in an extended warranty or the Maintenance*PLUS* maintenance contract, contact your sales representative to discuss the options.

## 14.2 Service Return Procedure

If you have questions, want a quick problem diagnosis, or need to return your *Genesis-II Select Directional* to the factory.

- Call Decatur Electronics Customer Service and ask to speak with a Customer Service Representative. Have the serial number of the radar unit ready.

Phone: 800.428.4315

Fax: 217.428.7508

If you need to return your radar unit to Decatur Electronics:

- Ask to arrange for a Return Authorization Number. You will need to give the serial number of the radar that is to be serviced. The serial number is located on the back of the main computer unit.
- Return ALL of the *Genesis-II Select Directional* parts in the original packaging (transportation prepaid).
- If so directed, include a note describing the problem and/or the incident that resulted in the problem. Failure to do so can delay the return of your radar device.
- Based on the information that you have given, the Customer Service Representative will issue you a return authorization (RA) number. Write the RA number on your note and shipping label.
- Return the system to:

Decatur Electronics, Inc.

715 Bright Street

Decatur, IL 62522 USA

RA# XXXXXX

The customer is responsible for the shipping charges to send the system to Decatur Electronics, Inc.

If we receive a system from a customer COD that is still under warranty, we will charge the customer for the amount of COD freight charges plus an additional 10% for handling after we repair the system. Also, we will add COD and a 10% handling fee to the repair bill for out-of-warranty repairs.

The customer is responsible for all shipping charges to the Decatur service location. Decatur does not accept incoming COD shipments. Decatur Electronics will pay the freight (up to \$10.00 US) for shipping the system from the repair facility to the customer, provided the system is still under warranty. We will charge the customer for any shipping charges above the initial \$10.00. If you want to ship your package express or next day air, we will invoice you for these freight charges.

If your radar is out of warranty and you would like to know the cost of repair prior to the actual repair work being performed, Decatur would be happy to give you a repair estimate. To obtain an estimate, request it either on the paperwork you submit with the radar device when you send it in for service or when you obtain a Return Authorization (RA) number. Decatur provides estimates only upon request.

The initial charge for an estimate is currently \$50.00 per unit if your radar gun is not under warranty, plus the return shipping and handling fees. If, after reviewing the estimate cost, you decide not to have your radar repaired, you will be invoiced a \$50.00 minimum charge. If you decide to have your radar gun repaired, you do not owe the estimated charge (the charge is waived) and only pay the amount stated in the estimate.



## 15. How to Order Additional Products

You can order upgrades (when available) to the *Genesis-II Select Directional* from Decatur Electronics as well as cases, power supplies, tripods, different cable lengths and mounting brackets. To see product descriptions or to order products, visit the Decatur Electronics Web site at [www.decaturradar.com](http://www.decaturradar.com) or contact the Decatur Electronics sales office at 800.428.4315.

<b>Antenna cables (An 8-ft front and 16-ft rear antenna cable is good with most vehicles)</b>		
4-ft. (1.2 m) antenna cable	S769-117-0	\$80.00
8-ft. (2.4 m) antenna cable	S769-105-0	\$90.00
16-ft. (4.8 m) antenna cable	S769-118-0	\$95.00
22-ft. (6.7 m) antenna cable	S769-115-0	\$100.00
<b>Front and rear antenna mounting bracket</b>		
Windshield bracket (comes standard with <i>Genesis-II Select Directional</i> order)	S758-38-0	\$25.00
Universal window bracket	S758-33-0	\$50.00
Deck mount (mounts on flat surface)	S758-34-0	\$35.00
Visor bracket (mounts on sun visor)	S758-40-0	\$25.50
Glue-on bracket (mounts on windshield)	S773-235A-0	\$25.50
<b>Communication cable (optional, connects radar to an external device)</b>		
10-ft. (3 m) cable (connects to IBM format PC and some video systems)	P769-116-0	\$70.00
<b>Carrying Case</b>		
Cardboard packing box / carrying case	P1025-36	\$40.00
Hard case with cut-out foam	P801-20	\$70.00
<b>Interconnect cable for connecting computer unit to detachable display unit (optional)</b>		
9-ft. (2.7 m) interconnect cable	S769-116-0	\$15.00

<b>Interconnect cable for use in separating detachable display from computer unit or for use in connecting communications port to other equipment</b>		
10-ft. (3 m) interconnect cable	S769-116-0	\$15.00
<b>Mounting bracket for use with detachable display or the computer unit</b>		
Detachable display bracket	S758-51-0	\$15.00



## Appendix A Communications Port

The RS232 communications port (COM) is located on the rear panel of the computer unit. The serial communication has the following characteristics (8:n:1) and is transmit only:

- One (1) start bit
- Eight (8) data bits
- No parity
- One (1) stop bit
- Transmission at 1200 baud

The *Genesis-II Select Directional* transmits data as ASCII symbols in the following digit sequence:

Target	Patrol
[hundreds][tens][ones]	ASCII [hundreds][tens][ones] carriage return<CR> (<CR> = ASCII decimal value 13)

The *Genesis-II Select Directional* sends the data in this sequence when the TARGET or PATROL speed display changes, or when the MODE or antenna (ANT) selection changes. During the test sequence the target and patrol speeds transmit, but the display segment check data do not.

When you press the LOCK button, the *Genesis-II Select Directional* transmits the following digital sequence

[hundreds][tens][ones]<CR>  
(<CR> = ASCII decimal value 13)

## Appendix B Menu Feature

The menu feature allows the operator to fine tune some of the settings of the radar. To activate the menu feature, press and hold the TEST button down until MENU is displayed in the mode window. Pressing OPTN steps through the menu items and the antenna ▲/ ▼ buttons change the settings. Pressing the TEST button again exits the menu feature and saves the settings.

Feature	Setting	Function
LOSP	4, 25 (km/h)	Low Speed - The minimum speed that the radar will process in stationary mode. Default is 25 km/h.
BEEP	ON, OFF	Beep - Beeps when button is pushed on the hand remote. Default is ON.
UNTS	km/h, mph	Display units - Measure speeds in km/h or mph. Factory set based on order.
COMX	0 through 5	Serial Port Communication Protocol - Selects protocol for interfacing to MDT, signs, etc. 0 - no output 1 - Decatur format 2, 3, 4, 5 - Reserved (no output) Default is 1.
FSTL	ON, OFF	Fast Lock - Allows the locking of a target if FAST mode is active. Default is ON.
HAR	ON, OFF	Harmonic Indicator - The radar displays “ <u>H</u> ” in the target window in the presence of a patrol harmonic. If turned off, the target window is blank. Default is ON.
SDSS	4, 8, 12 (km/h)	Same Directions Separation Speed - Sets the minimum separation speed that the radar will process in Same Direction mode. Default is 4 km/h.

## Appendix C Radar Case Law

### The Offence of Speeding (General)

R. v. Hickey (O.C.A.) 1976

Speeding is an offence of absolute liability. Defence of reasonable mistake of fact is not available.

R. v. Hickey (O.H.C.J.) 1976

Speeding - defendant's speedometer inaccurate - Court held speeding was a strict liability offence to which defence of reasonable mistake of fact did exist.

NOTE: OVERTURNED ON Appeal, See: R.v. Hickey (O.C.A.) 1976

R. v. Cunningham (O.H.C.J.) 1979

Accused misread speed limit sign and believed he was in a higher speed limit zone. HELD: Accused's mistake was a mistake of law, which is no defence to the charge of speeding.

R. v. Naugler (N.S.S.C.) 1981

Speeding is an offence of absolute liability, to which mistake of fact is no defence.

R. v. Bigioni (O.C.A.) 1988

ISSUE: What evidence is required to satisfy burden on crown prima facie in prosecution of charge of speeding when evidence obtained by radar?

The Ontario Court of Appeal affirmed that the evidence adduced at trial was sufficient prima facie evidence of speeding. (Refer to transcript of trial proceedings for particulars of evidence adduced)

R. ats. Sim (O.C.A.) 1988

See transcript of evidence at trial

- no evidence of visual observation
- no evidence of officer's training and qualifications
- no evidence tests performed on radar unit conformed with manufacturer's specifications
- no evidence as to accuracy of tuning forks
- no evidence radar units "is capable of accurately measuring the speed of moving motor vehicles

Held on appeal: Evidence before trial Court was sufficient to support conviction.

R. v. Grainger (O.C.A.) 1958

Speed by radar: Counsel argued it must be established that radar, when properly used, was capable of registering speed of a motor vehicle on a highway and that the machine was in good working condition and was properly used.

HELD: On summarized evidence it was implicit that radar when properly used is capable of registering speed of motor vehicle and at time was being properly used and in good working order. As defence merely claimed but did not show machine subject to weaknesses, conviction proper on weight of evidence.

R. v. Werenka (Alta. Q.B.) 1981

ISSUE: What evidence Crown must establish to prove prima facie case where speed by radar.

HELD: Crown only had to prove prima facie case. Not obliged to demonstrate that the instrument was capable of accurately registering speeds over the entire range of the instrument where there was no evidence to throw doubt on the officer's evidence.

1. qualified operator
2. tested and accurately measured the speed of the appellant's vehicle
3. evidence prima facie notwithstanding that the officer did not have a detailed knowledge of the working of the radar set.

R. v. Joudrey (1992) Nova Scotia Prov. Court

The accused was charged with speeding contrary to s. 106(2) of the Motor Vehicle Act. The night of the alleged offence was foggy and drizzly. The accused insisted that he was not driving over the speed limit and challenged the accuracy of the RADAR readings. His lawyer cross-examined the RADAR operator and, in doing so, referred to a textbook, “the Law of Speeding and RADAR”, and specifically to passages stating that certain atmospheric or environmental conditions could give spurious readings. The court did take judicial notice of the passages in the textbook and the accused was acquitted.

Griffin v. the Queen (N.S. Cnty. Ct.) 1980

Officer testified the appellant traveled at 107 kilometres in a zone marked for a maximum of 80 kilometres. He neither described the speed in terms of “kilometres per hour”, nor did he describe the purpose or functioning of the radar gun. HELD: Judicial notice could be taken of the functioning of the radar gun. While the description of the speed was imprecise, the intended meaning was clear.

R. v. Longmire (1993) Nova Scotia Supreme Court (Appeal Div.)

The appellant’s conviction was affirmed on appeal. The appellant appealed further, arguing that the trial Judge erred in his interpretation and application of s. 88(5) of the Motor Vehicle Act and that the Crown’s refusal to provide him with a copy of the RADAR operation manual violated his rights under ss. 7 and 11(d) of the Charter, preventing him from making full answer to the charge. Defence counsel indicated that his reason for asking for the manual was “so that the defence can make itself familiar with the particular operation of this RADAR unit and in order that we can intelligently cross-examine the Crown with regards to how he operated the RADAR on that day.” He also wished to have the manual to review sources of interference that may make the unit susceptible to inaccuracies. In addition, the testing procedure was sought for review. The Crown, in response to the preliminary motion, indicated that it would not provide a copy of the manual, but would consent to an adjournment so the defence could hire an expert in the operation of the RADAR machine. The trial Judge declined to order a stay, as defence requested, but did grant an adjournment so that defence counsel might obtain the manual from another source. Defence counsel did not pursue the matter of disclosure

on the adjourned date, nor did they cross-examine the officer with respect to the operation of the RADAR. The appellant did not lay a rational basis or factual foundation for his claim for disclosure. In an absence of an air of reality to the request for production, there was no evidence of a breach of the Charter. The appeal was dismissed.

R. v. Windrem (May 27, 1986, Brampton Prov. Off. Appt. Ct.)

Defence agents/counsel use this case to support their argument that there must be evidence before the Court that the tests conducted on the radar device were in accordance with the accepted manufacturer's technique. It is apparent from the Judgment that the appeal was allowed as the Justice of the Peace at trial misdirected himself on the evidence. The J.P. in his reasons for judgement found that the officer had checked the radar before and after use by the accepted manufacturer's technique. That evidence was not before the J.P. at trial.

R. v. Furlong (P.O.A.) 1985

Defence agents/counsel use this case to support their argument that the officer must state in evidence "I tested the radar..." It is apparent from the Judgment on appeal, that the appeal was allowed due to the fact that the J.P. at trial misdirected himself on the evidence before him. The J.P. found as a fact that the officer was the person that did the testing, because there was no one else in the police car. There was no such evidence before the J.P. at trial.

Owusu v. R. (P.O.A. Appeal Crt.) 1988

1. It is not mandatory for the speed limit sign to display a tab sign below.  
See Reg. 486 (d) "MAY" display...
2. There is no statutory provision in Ontario Highway Traffic Act, for the admissibility  
Of a certificate as to the accuracy of the tuning forks. (Alberta Court of Appeal decision Re: speeding and necessity to file certificate distinguished)

R. v. Wagner (1999), Ontario Court of Justice

The appellant in this case as charged for speeding and requested a

trial. The officer in charge of the matter encouraged the woman to plead guilty in exchange for a reduction of the offence by 10 kph. The officer later had a paralegal approach the woman and offer his unsolicited opinion that she was unlikely to be successful at trial and should accept the officer's reduction, which she did and plead guilty. She later appealed the conviction citing that she had been intimidated into the agreement. In his ruling, Judge K.P.Evans stated, "This long time practice of having the charging police officer attempt to negotiate a plea or arrange a settlement of a case such as this, is archaic and fraught with dangers to the integrity of our judicial system as it stands today. The responsibility for offering or accepting any plea negotiations are solely within the jurisdiction of the Provincial Prosecutor assigned to the said Court." The appeal was granted and a dismissal was ordered.

R. v. Howe (P.O.A. Appeal Ct.) 1988

Requirement in Alberta case for a certificate as to accuracy of tuning forks is unreasonable and not necessary. See R. v. Bourque (1985 Alta. Q.B.)

R. v. Meyer (P.O.A. Appeal Ct.)

On appeal, Court held that there must be evidence that the radar device was "capable of registering the speed of vehicles".

R. v. O'Reilly (Alta. Dist. Ct.) 1979

Where Crown failed to adduce evidence that the radar set was capable of accurately measuring the speeds and that the tests were approved tests, which evidence would have been given by the officer who testified, then appeal must be allowed and conviction set aside.

NOTE: Speeding is an offence of absolute liability. This means that MENS REA (a guilty mind) is not an element that must be proven. Guilt follows proof of the ACTUS REUS (proscribed act).

- Because speeding is an absolute liability offence, a defence argument that, owing to a defective speedometer the accused honestly believed that he or she was not exceeding the speed limit, would not be successful.

R. v. Keenan (1994) British Columbia Supreme Court

The accused appealed a conviction for speeding. One of his three grounds for appeal was that there was insufficient evidence of the accuracy of the RADAR measurement showing that the accused was speeding.

The police officer testified that, prior to starting his shift, he had tested the device using a tuning fork. He also testified that he visually estimated the speed of the vehicle to be 90 kph: the RADAR device displayed a speed of 92 kph. There was ample evidence to support the justice of the peace's conclusion that the measured speed was accurate. It was not necessary that the accuracy of the tuning fork be proven.

R. v. Cook (1994) Nova Scotia Supreme Court

The accused was convicted of speeding based on a reading from a moving RADAR. The accused appealed arguing that the trial Judge erred in finding that a prima facie case as to the accuracy of the RADAR equipment had been established since no certificate was produced attesting to the frequency used by the tuning fork to calibrate the machine. He also argued that the Crown failed to make full disclosure in that it failed to give notice that it intended to give expert testimony from the officer/RADAR operator. Finally, he argued that the Crown failed to prove that signs were erected and maintained imposing an 80 kph speed limit at the time and place in question. The appeal was dismissed.

The Motor Vehicle Act makes it clear that, whether posted or not, there is a prima facie speed limit on all highways in Nova Scotia of 80 kph. The accused conceded that he had the entire file of the Crown. There was no withholding of any information; there was no expert's report and no need for the preparation of any expert report. The accused argument as to the accuracy of the instrument would be persuasive if the alleged offence was one in which there was a marginal difference between the speed limit (80kph) and the speed of the accused (130kph) and if there was no other persuasive evidence.

R. v. Lounsbury (1993) Manitoba Court of the Queen's Bench

The accused was charged for speeding. The RADAR operator testified

at trial that it was his usual practice to test the unit both before and after issuing an offence notice, but he had no independent recollection of performing the tests in this case. He made a note in his notebook that he had performed a test or tests, but did not note the time of the test. The accused was convicted and appealed. The appeal was allowed.

Evidence as to the operator's usual practice did not constitute proof beyond a reasonable doubt that the RADAR device was operation in this case. All that could be safely inferred from the RADAR operators testimony and notes was that he tested the RADAR device and found it to be in good working order at some point or points during the relevant shift. As a result, the appeal was allowed and the conviction was quashed.

R. v. Friedlan (1993) Ontario Court of Justice (Prov. Div.)

Where a person is charged with speeding in a construction zone, the onus is on the Crown to prove that the portion of the highway travelled was designated as construction zone under s. 128(8) of the Highway Traffic Act. Pursuant to s.128(9) of that Act, such designation is not a regulation within the meaning of the Regulations Act.

In this case, despite the fact that the officer testified that this was a construction zone in question and the area was clearly posted as an 80 kph zone, the court allowed the conviction, but amended the offence to indicate the non-construction zone speed limit of 100 kph.

Quebec c. Robitaille (1991) Quebec Court of Appeal

A police officer who was following the accused's vehicle testified that the speedometer of his own car recorded a speed of 140 kph while the speed limit was 90 kph. At the end of the Crown's case, the accused moved for non-suit on the grounds that the speed at which he was travelling was not established. This argument was rejected and the accused was convicted. On appeal by trial de novo, the Superior Court quashed the conviction. The Crown appealed.

The appeal was allowed and the conviction was restored. If a speed established by a RADAR device is sufficient prima facie evidence, a fortiori is the speed recorded by the speedometer. Expert evidence establishing the speed at which the accused was driving is not required, since the accused had not adduced evidence raising a reasonable doubt

as to the accuracy of the police officer's speedometer. Therefore, the conviction was justified and had to be restored.

Quebec c. Mason (1988) Quebec Superior Court

The accused was convicted of speeding. He appealed, challenging the RADAR evidence. The appeal was dismissed. Leaving aside cases in which calibration, verification of calibration, method of operation, qualifications of the operator or other factors cast a doubt on the evidence of operation and capabilities of a device, the testimony of a qualified operator can found a conviction. Once the conditions precedent are met the fallibility of the device goes to weight. It is unnecessary to show scientifically the principles of RADAR.

R v. Strong (1988) Nova Scotia County Court

The accused was acquitted of a speeding charge. Although the trial Judge accepted the evidence of the police officer with respect to the actual speed of the accused's vehicle as indicated by the RADAR, he entered an acquittal on the basis that the Crown had failed to prove that the accused had passed a speed zone sign indicating the posted speed in the area in question. The Crown appealed. The appeal was allowed.

There was requirement in the relative statutory provision that speed zone signs be erected so as to be always visible to a motorist traversing a section of highway covered by the speed approved for that area. Common sense dictated that such could not have been the intention of the Legislature - otherwise such signs would have to be erected at each street intersection and at various intervals along all the province's roadways.

Quebec c. Rannaud (1988) Quebec Provincial Court

The accused was stopped for speeding. The sole evidence was from a RADAR operator. The operator testified that he took an instruction course and that he frequently used the device on duty. He indicated that on the night in question he manually and electronically verified the accuracy on three occasions. He also verified the devices operation after stopping the accused. Manual checks were done by means of a tuning fork. The accused was convicted.

No expert was needed to provide evidence regarding calibration. The

absence of legislative approval of the use of tuning forks did not invalidate its effectiveness on calibration. If the operator carries out tests correctly and in conformity with recognized methods, he can speak to accuracy of the device and its proper functioning. An operator need not be familiar with the relevant laws of physics. Here, the results of the test confirmed the accuracy.

## **TRAINING/QUALIFICATIONS**

### R. v. Wolfe (B.C.C.C.) 1979

The officer had some training and experience operating radar set, but training “fell short” which cast doubt on the accuracy of the device and its results.

### R. v. Brewer (May 19, 1988, Prov. Off. Ct. Nwkt, Ont.)

At trial, officer had stated in-chief that he was a qualified radar operator and that he had received some basic training from an experienced officer in the use of the radar. In cross-examination, the officer’s qualifications were challenged.

HELD ON APPEAL: In this case, the officer could not be regarded as a “qualified radar operator” and therefore, a prima facie case was not made out.

NOTE: Can be distinguished on the facts of this case, as officer had no formal training.

### R. v. Waschuk (Sask. Q.B.) 1970

Judicial notice of radar: Judicial notice may only be taken of facts which are known to intelligent persons generally, therefore, judicial notice may not be taken of meaningfulness of tests.

Radar operator should be able to give evidence as to whether the machine is in good working order and capable of recording the speed of the vehicle being tested.

### R. v. Karpetz (Unreported, March 18, 1982 (Prov. Off. App. Ct.))

His Honour, Provincial Court Judge W. Hryciuk.

Failure to show the radar reading to the defendant does not make the charge bad. No duty is cast upon the officer to show the reading on the radar screen. As a matter of courtesy, he can advert the defendant's attention to the reading whether the defendant asked to see it or not.

R. v. Axler (Unreported August 20, 1981, Prov. Off. App. Ct.)

His Honour, Provincial Court Judge R.B. Dnieper.

Radar alone is good evidence. After 42 years of use, the courts will accept as prima facie evidence, the accuracy of radar devices. No longer is radar merely corroborative evidence. It is now primary evidence.

Before the prima facie rule applies, it has to be established in evidence that:

1. the radar machine was in proper working order, and
2. the radar operator was qualified to operate the machine in question.

At all times, the onus is on the crown to prove its case beyond a reasonable doubt.

R. v. Seymour (Unreported, June 16, 1982 Prov. Off. App. Ct., County of Huron, Ont.)

The crown must establish in evidence that the officer is a person who has been properly trained in the use of the device and further, that at the time in question the radar device was operating accurately.

R. v. Lehane (1982, 15 M.V.R. 160 (Ata Q.B.))

There was no evidence that the device had been recently tested to determine whether or not the device was operating properly and was capable of accurately registering speeds.

The Judge stated in his opinion it would be easy matter for police to test the accuracy of radar devices by means of a calibrated tuning fork or by some other means before and after a duty shift during which the device was used.

R. v. Ellision (Feb. 11, 1987, British Columbia County Court)

The accused was convicted of speeding. He appealed on the ground that the denial by the police officer who stopped his car of his request to see the radar reading erasure of the reading by the officer contravened the best evidence rule and violated his right to make full answer and defence under section 7. of the Charter.

Held - The appeal was dismissed.

The best evidence rule was confined largely to documentary evidence; apart from documentary evidence it was not usually applied to exclude secondary evidence otherwise admissible. There was no suggestion of an attempt to conceal evidence. The accused had been given the opportunity to make full answer and defence.

R. v. Hallett (May 3, 1988, N.S. Co. Ct.)

Appeal by accused from his conviction on a charge. The accused's vehicle had been clocked on radar and the accused now argued that the police officer operating the radar device had never been properly qualified as an expert to do so - No objection had been raised as to the qualifications of the police officer during his evidence at trial nor was the officer cross-examined as to his qualifications. In the circumstances it was not necessary for the Crown to establish that the police officer was an "expert" as the evidence which he was being asked to give was not in the nature of an opinion but more in nature of observations. The trial judge clearly found that the police officer could operate the machine, that the machine was working properly, and that there was no evidence to show that it's reading was inaccurate. There was no basis to disturb those findings on appeal.

R. v. McDonald (Feb. 26, 1987, B.C. Co. Ct.)

Opinion Evidence - Whether radar operator giving "expert" evidence. The trial judge did not err in finding police officer who testified concerning his operation of radar was not an "expert" so as to require 30 days' notice in writing of his proposed evidence under s.11 of the Evidence Act. Accordingly, the officer gave evidence only of a technical skill, which did not reach expert status.

## **User Notes**



## Index

- air bag deployment zone 10
- air conditioner 16
- angular interference 43
- ANT (FRONT and REAR) buttons  
7,18,34,40
- Ant? 18
- antennas 5,6,7,12,18,34,35,40,54
  
- batching 45
- beep 39
- blanking patrol speed 38,40
- brackets 6,10
  
- cables 6,9,11,12
- care 52
- case law 59
- CITY 37
- city/highway option (OPTN) 37
- cleaning 52
- communication (COM) port  
41,60,68
- computer/display unit 6,8,31,53
- connectors 9,11
- controls 36
- cosine error effect 43
  
- Decatur Electronics Customer  
Service 63
- Decatur products 66
- digital signal processing (DSP)  
5,45
- display windows 32
- Doppler 38,42,46
  
- electromagnetic interference (EMI)  
45
- environment 54
- erratic speeds 42
- error messages 32
  
- FAIL 50
- fan interference 16,44
- FAST button 7,26,33,39
- Faster operating mode 7,25,33
- FCC 57,60
- feedback 45
- freight charges 64
- frequently asked questions (FAQ)  
60
- FRONT button 7,16,18,31,34,40
  
- guarantee 62
  
- hand-held remote control 5,6,36,53
- heater 16
- high-speed option 56
- HWY 37
  
- in-car video systems 41,60
- initial setup 8
- installation check 16
- interference 16,42
  
- K-band Directional antennas  
5,35,53,54
  
- law (radar cases) 59
- legal requirements 57
- lights 33
  - FASTER 31,33
  - FRONT 31,34
  - RANGE 28,31
  - REAR 31,34
  - SLOWER 31,34
- LOCK button 7,27,32,36,40
- locked speeds 7,27,32,40
- LOCKED window 7,27,31,32,40
- low voltage (LowV) 32

- maintenance 63
- MODE button 7,23,36,40
- MODE window
  - 17,18,23,24,31,32,37,38
- mounting hardware 6,10,13
- Moving Mode Opposite Direction
  - 23,56
- Moving Mode Same Direction
  - 24,56
- multi-path beam cancellation 46
  
- operating modes 19
- OPTN button 36,37
  
- PASS 17,50
- patrol harmonics 46
- Patrol speed blanking 38,40
- Patrol speed lock 38,40
- Patrol speed recall 38,40
- Patrol speeds 24,40
- PATROL window 24,31,32
- PCs 41
- performance tips 42
- power 12,17,60
- PWR button 7,17,36,37
  
- quick start 7
  
- radar (defined) 42
- radio frequency interference (RFI)
  - 32,46
- range 28,36,60
- RANGE button 28,36,39
- REAR button 7,18,40
- recalling patrol speed 38
- remote control 36
- repair record 65
- return policy 63
  
- RMT? 32
- road test 51
- RS232 communications port
  - 41,60,68
  
- sensitivity level 28,39
- serial communication port 41,68
- service 62
- shadowing 37,47
- shipping and handling charges 63
- specifications 53
- speed accuracy tests 50
- speed computation 56
- speed range 56
- speed signs 41,61
- sports gun 61
- spurious speeds 42
- squelch (SQL) button 36,38
- Stationary Mode 19,56
- Stopwatch Mode 29,37
- storage 52
- system error (SYS) 17,32,38,61
  
- targets
  - acquisition range 28
  - evaluating multiple targets 26
  - next strongest target 26
- TARGET window
  - 7,20,24,27,31,32,33,40
- temperature 10,54
- TEST button 36,38,50
- test functions
  - circuitry 38,50
  - display 50
  - road 51
  - self test 38,50
  - speed simulation 50

tracking history of target speed

27,40

troubleshooting 60

upgrades 66

user notes 81

vehicle ignition interference 49

Velcro 10

video systems 41,60

voltage 55

VOLUME button 36,39

warranty 62

